



# **The Elmer A. Sperry Award**

## **2004**

**FOR ADVANCING THE ART OF TRANSPORTATION**



## The Elmer A. Sperry Award

The Elmer A. Sperry Award shall be given in recognition of a distinguished engineering contribution which, through application, proved in actual service, has advanced the art of transportation whether by land, sea or air.

In the words of Edmondo Quattrocchi, sculptor of the Elmer A. Sperry Medal:

*"This Sperry medal symbolizes the struggle of man's mind against the forces of nature.*

*The horse represents the primitive state of uncontrolled power. This, as suggested by the clouds and celestial fragments, is essentially the same in all the elements. The Gyroscope, superimposed on these, represents the bringing of this power under control for man's purposes."*

Presentation of

# The Elmer A. Sperry Award for 2004

to

**JOSEF BECKER**

*for the invention, development, and worldwide implementation of the Rudderpropeller, a combined propulsion and steering system, which converts engine power into optimum thrust. As the underwater components can be steered through 360 degrees, the full propulsive power can also be used for maneuvering and dynamic positioning of the ship.*

by

The Board of Award under the sponsorship of the:

American Society of Mechanical Engineers  
Institute of Electrical and Electronics Engineers  
Society of Automotive Engineers  
Society of Naval Architects and Marine Engineers  
American Institute of Aeronautics and Astronautics  
American Society of Civil Engineers

at the

SNAME

Maritime Technology Conference and Expo

Banquet

October 20, 2005

Houston, Texas

# Josef Becker

Josef Becker was born on 14 July 1897 in Spay on the river Rhine near Koblenz. On 21 November 1921, at the age of 24, shortly after his marriage to Magdalena Karbach, he founded his craftsman's enterprise. He had acquired the necessary technical qualifications for doing so as an apprentice fitter in his parents' company and during his further training at a Koblenz yard.

Josef Becker set up a small workshop in the shed of an old farmhouse. The hacksaw he made to qualify as a master mechanic, a foot-operated drill and an old lathe were the first machines he used to do any job he was offered: he overhauled pumps, installed water pipes and occasionally repaired cars.

Shortly after founding the company, Josef Becker hired two workers and on 1 July 1922 the first apprentice started his training. By setting up a small iron foundry in 1923/24 and producing his own castings, Josef Becker made himself independent of external supplies. Besides pumps, the first products were agricultural implements and machines.

In 1925 Josef Becker built the first shallop of his own design. This unsinkable tender represented the first step from land to water. The shallop earned the praise of experts and orders were placed by Rhine bargemen and shipping companies. Just three years later, the first motorboat was launched, followed by further victualling boats and small passenger craft.

In the mid '30s, the production of shallows and larger motorboats was in full swing, and the old factory was bursting at the seams, so Josef Becker purchased the present company site at Rhine kilometre 578.5 in Spay and, in 1935/36, built a slipway with an electric hoist, a boat-building shop with modern special-purpose machines, a joiner's shop, a forge and other workshops.

The section of the Rhine at the new company site is called SCHOTTEL and this is the name that Josef Becker chose for his yard and its products.

Josef Becker died on 20 August 1973. His name lives on as the founder of a company that has become inextricably linked with the world of shipping. In designing and building the world's most successful series-produced boat for commercial shipping and in inventing the trail-blazing propulsion and steering system - the SCHOTTEL Rudderpropeller - Josef Becker and his team performed truly pioneering work for the shipping industry.



JOSEF BECKER

(1897 - 1973)

## THE ACHIEVEMENT

In the late '40s Josef Becker revived an old idea that had been occupying his thoughts: The propulsion plant took up too much space in floating objects like barges, ferries and motorboats. He wanted to find a system that could be space-efficiently installed and easily maintained, as well as offering good maneuvering properties.

Based on his experience in building transmissions for farming tractors and his ideas for improving outboard motor propulsion, he experimented with the bevel gears of old car axles and finally developed a Z-type drive system on which the underwater section with the propeller could be steered endlessly through 360 degrees. In 1951 the first SCHOTTEL Rudderpropeller (SRP) suitable for transmission of 150 HP was born and the company's own motorboat - the "Magdalena" - was equipped with this propulsion system.

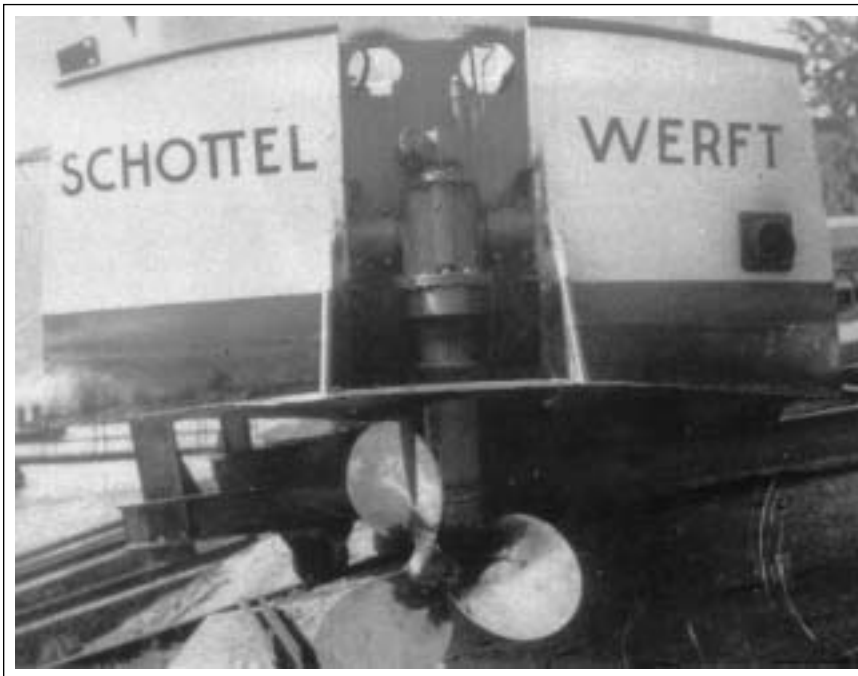

**“Improvements relating to Outboard Motor Propulsion  
and Steering for Boats” (Patent No. 793658)**

Patent  
No. 793658



 Elizabeth the Second by the Grace of God of the United Kingdom of Great Britain and Northern Ireland and of Her other Realms and Territories Queen, Head of the Commonwealth, Defender of the Faith: To all to whom these presents shall come greeting:

WHEREAS Josef Becker, of German Nationality, of No. 120 Mainzerstrasse, Chemnitz on the Rhin, Germany

(hereinafter referred to as the said applicant) hath proved that a patent may be granted unto him for the sole use and advantage of us ourselves for Improvements relating to outboard motor propulsion and steering for boats

AND WHEREAS the said applicant (hereinafter together with his executors, administrators, and assigns, or any of them referred to as the patentee) hath declared that there is no lawful ground of objection to the grant of a patent unto him:

AND WHEREAS the complete specification has particularly described the invention:

AND WHEREAS We, being willing to encourage all inventions which may be for the public good, are graciously pleased to condescend to his request:

KNOW YE, THEREFORE, that We, of our especial grace, certain knowledge, and mere motion do by these presents, for Us, our heirs and successors, give and grant unto the said patentee our especial licence, full power, sole privilege, and authority, that the said patentee by himself, his agents, or licensees, and no others, may subject to the conditions and provisions prescribed by any statute or order by the time being in force at all times hereafter during the term of years hereby expressed, make, use, exercise and vend the said invention within our United Kingdom of Great Britain and Northern Ireland, and the Isle of Man, and that the said patentee shall have and enjoy the whole profit and advantage from time to time arising by means of the said invention during the term of sixteen years from the date hereunder written of these presents: AND to the end that the said patentee may have and enjoy the sole use and exercise and the full benefit of the said invention, We do by these presents for Us, our heirs and successors, strictly command all our subjects whatsoever within our United Kingdom of Great Britain and Northern Ireland, and the Isle of Man, that they do not in any wise during the continuance of the said term either directly or indirectly make use of or put in practice the said invention, nor in anywise imitate the same, without the consent, licence or agreement of the said patentee or writing under his hand and seal, on pain of incurring such penalties as may be justly inflicted on such offenders for their contempt of this our Royal command, and of being answerable to the patentee according to law for his damages thereby occasioned:

PROVIDED ALWAYS that these letters patent shall be revocable on any of the grounds from time to time by law ascribed as grounds for revoking letters patent granted by Us, and the same may be revoked and made void accordingly:

PROVIDED ALSO that nothing herein contained shall prevent the granting of licences in such manner and for such considerations as they may by law be granted: AND LASTLY, We do by these presents for Us, our heirs and successors, grant unto the said patentee that these our letters patent shall be construed in the most beneficial sense for the advantage of the said patentee.

IN WITNESS whereof We have caused these our letters to be made patent  
as of the thirty-first day of January  
one thousand nine hundred and fifty-six and so to be sealed

  
Gordon Grant  
Chancellor-General of Patents,  
Designs, and Trade Marks.



## Complete Specification (Patent No. 793658)

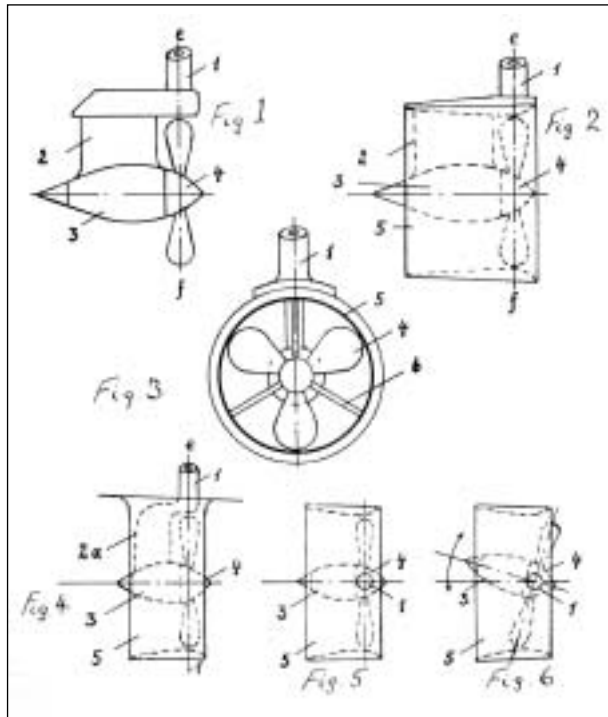

What I claim is:

1. Steerable propeller drive for boats with outboard motor propulsion, characterized in that the axis of rotation of the rudder pin extends in the plane of the propeller.
2. Steerable propeller drive according to Claim 1, characterized in that the propeller (4) and its underwater part (3) with the steering fin (2) are arranged within a nozzle (5) which participates in the steering movement of the underwater body (2, 3), the axis of rotation of the rudder pin (1), the vertical axis of the propeller (4) and the steering axis of the nozzle (5) being located in the same line.
3. Steerable propeller drive according to Claim 1, characterized in that the propeller (4) and its underwater part (3) with the steering fin (2a) are arranged within a stationary nozzle (5), the axis of rotation of the rudder pin (1) and the vertical axis of the propeller (4), located in the same line, being arranged in the narrowest part of the nozzle (5) and the propeller drive can be swung through an angle of 360° within the nozzle (5).



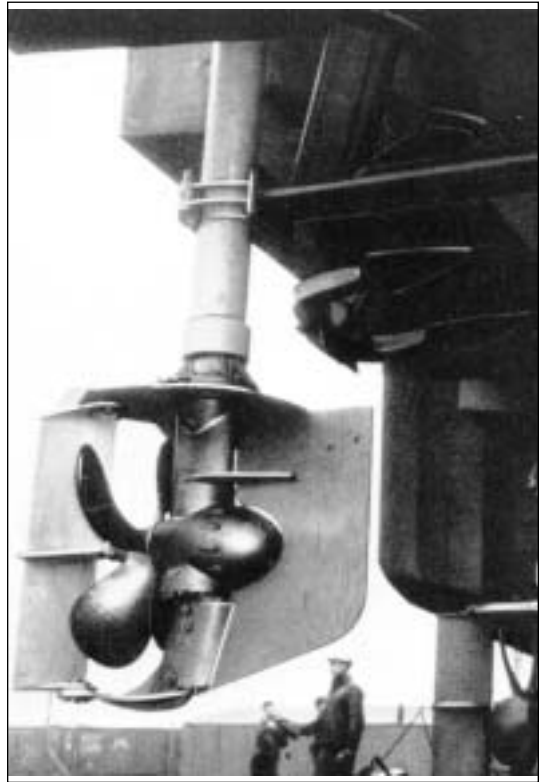
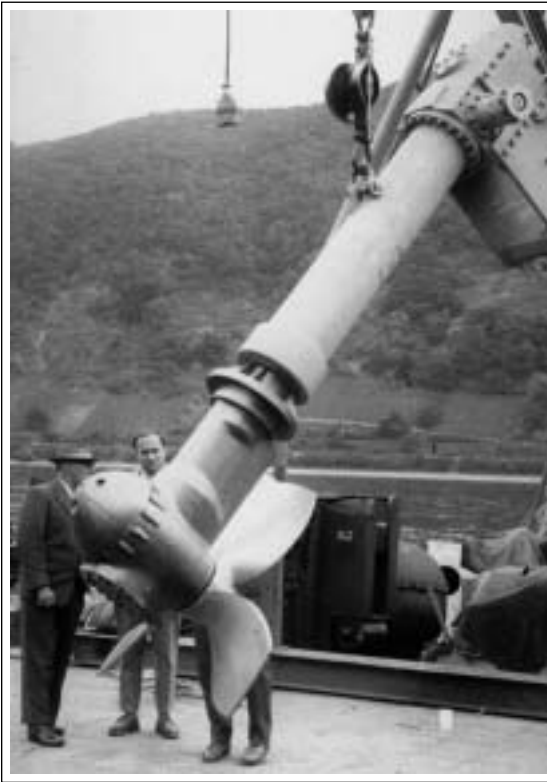

*Rudderpropellers in pull and push version*

The SCHOTTEL Rudderpropeller soon became known as a propulsion unit for small fast patrol craft built by the "SCHOTTEL Werft" for German police forces and similar government bodies.

In the beginning, the reliability of this new propulsion equipment was based mainly on the technical ability of the man behind the concept. He inspired confidence because he stood behind his products unconditionally, aided the customers if a Rudderpropeller did unexpectedly malfunction, and was open for discussion on suggestions from them for improvement. SCHOTTEL won itself a name for reliability and service.

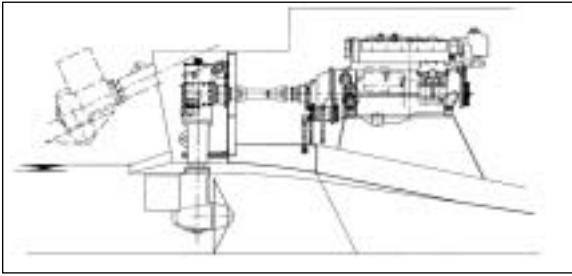

*Transom installation*

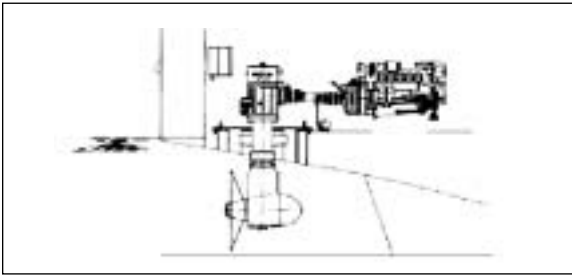

*Well installation*

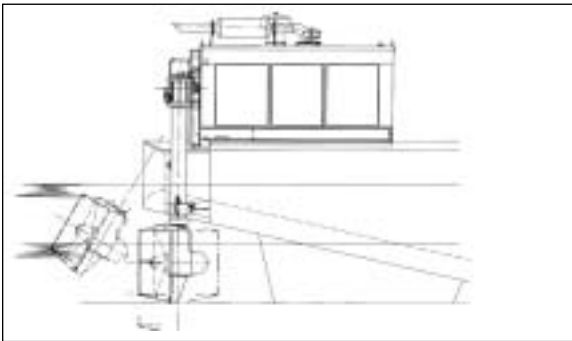

*Navigator installation*

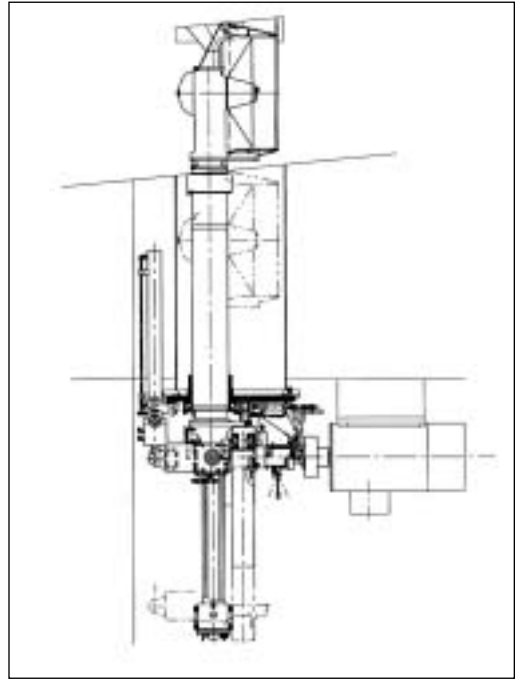

*Retractable unit*

**Installation variants**

*Rudderpropeller standard types*

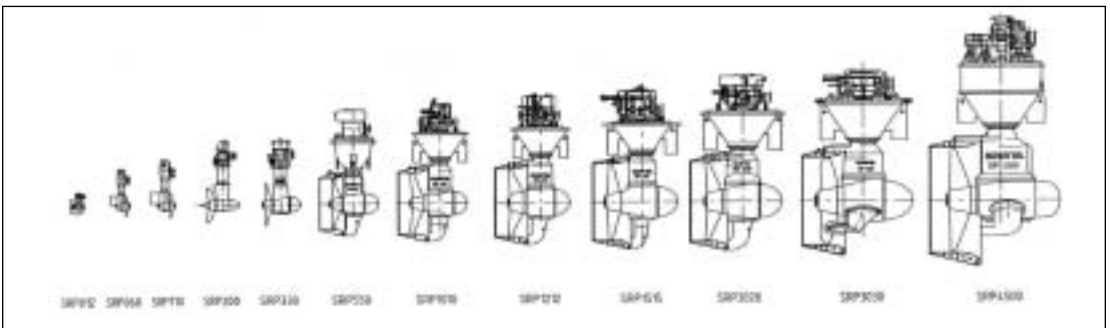



One classic area of application for Rudderpropellers is tugs. By 1967, “Janus”, the first tractor tug, was commissioned in Hamburg Harbour. Its two SCHOTTEL Rudderpropellers (342 kW each) were located in the front third of the vessel. The tractor tug arose from the idea of building a modern tug that would combine optimum maneuverability with a maximum of safety, towing power and economic efficiency. These goals were achieved through the use of SCHOTTEL Rudderpropellers.

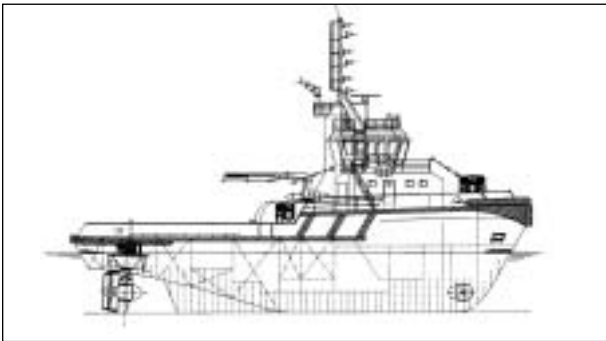

*ASD tug (Rudderpropellers in the stern)*

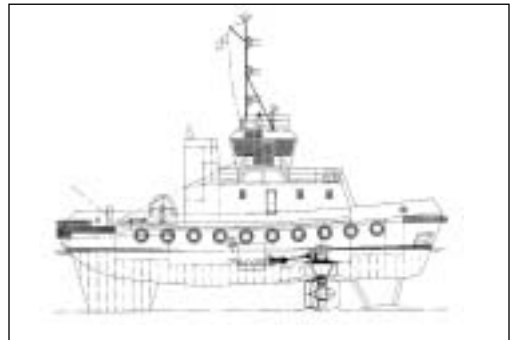

*Tractor tug (Rudderpropellers in the front third of the tug)*

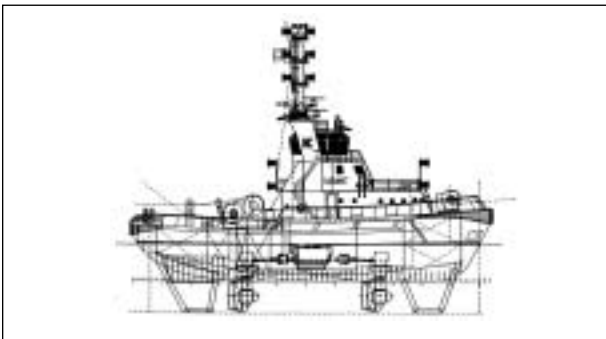

*Rotor tug*

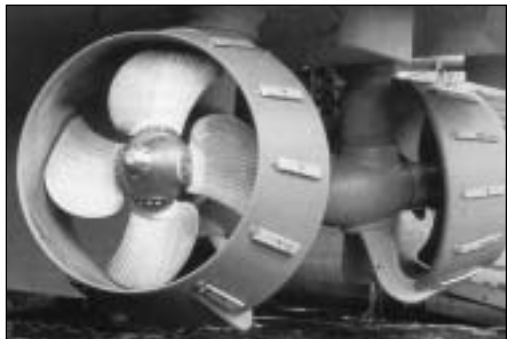

*SRP 1515 CP (2025 kW)*

Today, it would be hard to imagine the shipping world without the Rudderpropeller, and it remains the centerpiece of SCHOTTEL's product range. Over the years, SCHOTTEL engineers have developed additional application-oriented systems around the SRP.

A successfully optimized version of the SRP, the SCHOTTEL Twin Propeller (STP), has also become a classic SCHOTTEL product. The technology of the Twin Propeller, in which thrust is generated by two propellers rotating in the same direction on a single shaft, also served as a model for the Siemens-SCHOTTEL Propulsor (SSP), with power ratings up to 20 MW. With the SCHOTTEL Electric Propulsor (SEP), the company is offering, besides the SSP, an additional pod drive with power ratings up to about 5 MW.

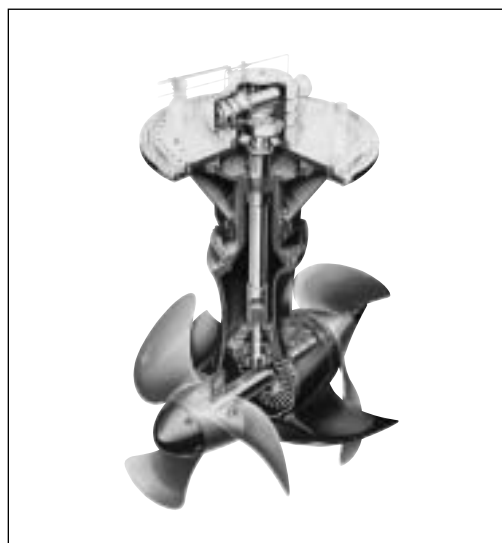
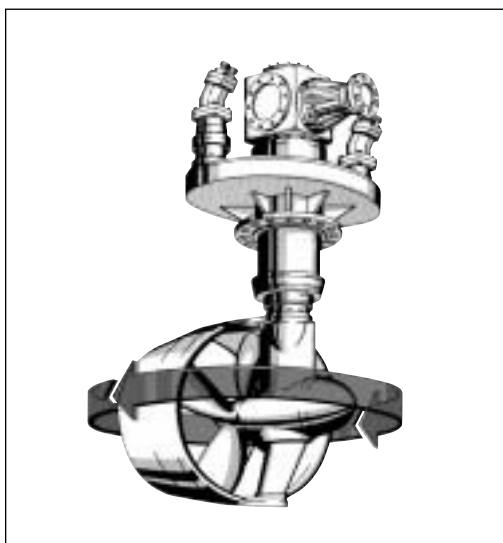

SCHOTTEL engineers have developed a new concept that combines the main technical and economic criteria of both mechanical Rudderpropellers and pod drives: the SCHOTTEL Combi Drive (SCD) with power ratings up to 3800 kW. In contrast to pod drives with an electric motor inside the underwater pod, the motor in the new propulsion system is integrated vertically into the support tube of the Rudderpropeller. This arrangement of the electric motor means that the new concept is similar to that of a Rudderpropeller with a vertical power input ("L system").

At SCHOTTEL, we can look back on a number of pioneering achievements which have benefited commercial shipping worldwide. The company's evolution from a small yard into a medium-sized industrial enterprise was based on the development some 55 years ago of what at that time was a sensational new propulsion system, the SCHOTTEL Rudderpropeller.



## Elmer A. Sperry, 1860-1930

After graduating from the Cortland, N.Y. Normal School in 1880, Sperry had an association with Professor Anthony at Cornell, where he helped wire its first generator. From that experience he conceived his initial invention, an improved electrical generator and arc light. He then opened an electric company in Chicago and continued on to invent major improvements in electric mining equipment, locomotives, streetcars and an electric automobile. He developed gyroscopic stabilizers for ships and aircraft, a successful marine gyro-compass and gyro-controlled steering and fire control systems used on Allied warships during World War I. Sperry also developed an aircraft searchlight and the world's first guided missile. His gyroscopic work resulted in the automatic pilot in 1930. The Elmer A. Sperry Award was established in 1955 to encourage progress in transportation engineering.

# The Elmer A. Sperry Award

To commemorate the life and achievements of Elmer Ambrose Sperry, whose genius and perseverance contributed so much to so many types of transportation, the Elmer A. Sperry Award was established by his daughter, Helen (Mrs. Robert Brooke Lea), and his son, Elmer A. Sperry, Jr., in January 1955, the year marking the 25th anniversary of their father's death. Additional gifts from interested individuals and corporations also contribute to the work of the Board.

Elmer Sperry's inventions and his activities in many fields of engineering have benefited tremendously all forms of transportation. Land transportation has profited by his pioneer work with the storage battery, his development of one of the first electric automobiles (on which he introduced 4-wheel brakes and self-centering steering), his electric trolley car of improved design (features of its drive and electric braking system are still in use), and his rail flaw detector (which has added an important factor of safety to modern railroading). Sea transportation has been measurably advanced by his gyrocompass (which has freed man from the uncertainties of the magnetic compass) and by such navigational aids as the course recorder and automatic steering for ships. Air transportation is indebted to him for the airplane gyro-pilot and the other air navigational instruments he and his son, Lawrence, together developed.

The donors of the Elmer A. Sperry Award have stated that its purpose is to encourage progress in the engineering of transportation. Initially, the donors specified that the Award recipient should be chosen by a Board of Award representing the four engineering societies in which Elmer A. Sperry was most active:

American Society of Mechanical Engineers  
(of which he was the 48th President);

American Institute of Electrical Engineers  
(of which he was a founder member);

Society of Automotive Engineers; and  
Society of Naval Architects and Marine Engineers.

In 1960, the participating societies were augmented by the addition of the Institute of Aerospace Sciences. In 1962, upon merging with the Institute of Radio Engineers, the American Institute of Electrical Engineers became known as the Institute of Electrical and Electronics Engineers; and in 1963, the Institute of Aerospace Sciences, upon merger with the American Rocket Society, became the American Institute of Aeronautics and Astronautics. In 1990, the American Society of Civil Engineers became the sixth society to become a member of the Elmer A. Sperry Board of Award.

Important discoveries and engineering advances are often the work of a group, and the donors have further specified that the Elmer A. Sperry Award honor the distinguished contributions of groups as well as individuals.

Since they are confident that future contributions will pave the way for changes in the art of transportation equal at least to those already achieved, the donors have requested that the Board from time to time review past awards. This will enable the Board in the future to be cognizant of new areas of achievement and to invite participation, if it seems desirable, of additional engineering groups representative of new aspects or modes of transportation.

### **THE SPERRY SECRETARIAT**

The donors have placed the Elmer A. Sperry Award fund in the custody of the American Society of Mechanical Engineers. This organization is empowered to administer the fund, which has been placed in an interest bearing account whose earnings are used to cover the expenses of the board. A Secretariat is administered by the ASME, which has generously donated the time of its staff to assist the Sperry Board in its work.

The Elmer A. Sperry Board of Award welcomes suggestions from the transportation industry and the engineering profession for candidates for consideration for this Award.

# PREVIOUS ELMER A. SPERRY AWARDS

- 1955** To *William Francis Gibbs* and his Associates for design of the S.S. United States.
- 1956** To *Donald W. Douglas* and his Associates for the DC series of air transport planes.
- 1957** To *Harold L. Hamilton, Richard M. Dilworth* and *Eugene W. Kettering* and Citation to their Associates for developing the diesel-electric locomotive.
- 1958** To *Ferdinand Porsche* (in memoriam) and *Heinz Nordhoff* and Citation to their Associates for development of the Volkswagen automobile.
- 1959** To *Sir Geoffrey de Havilland, Major Frank B. Halford* (in memoriam) and *Charles C. Walker* and Citation to their Associates for the first jet-powered passenger aircraft and engines.
- 1960** To *Frederick Darcy Braddon* and Citation to the Engineering Department of the Marine Division of the *Sperry Gyroscope Company*, for the three-axis gyroscopic navigational reference.
- 1961** To *Robert Gilmore LeTourneau* and Citation to the Research and Development Division, *Firestone Tire and Rubber Company*, for high speed, large capacity, earth moving equipment and giant size tires.
- 1962** To *Lloyd J. Hibbard* for applying the ignitron rectifier to railroad motive power.
- 1963** To *Earl A. Thompson* and Citations to *Ralph F. Beck, William L. Carnegie, Walter B. Herndon, Oliver K. Kelley* and *Maurice S. Rosenberger* for design and development of the first notably successful automatic automobile transmission.
- 1964** To *Igor Sikorsky* and *Michael E. Gluhareff* and Citation to the Engineering Department of the Sikorsky Aircraft Division, *United Aircraft Corporation*, for the invention and development of the high-lift helicopter leading to the Skycrane.
- 1965** To *Maynard L. Pennell, Richard L. Rouzie, John E. Steiner, William H. Cook* and *Richard L. Loesch, Jr.* and Citation to the Commercial Airplane Division, *The Boeing Company*, for the concept, design, development, production and practical application of the family of jet transports exemplified by the 707, 720 and 727.
- 1966** To *Hideo Shima, Matsutarō Fuji* and *Shigenari Oishi* and Citation to the *Japanese National Railways* for the design, development and construction of the New Tokaido Line with its many important advances in railroad transportation.



**1967** To *Edward R. Dye* (in memoriam), *Hugh DeHaven*, and *Robert A. Wolf* for their contribution to automotive occupant safety and Citation to the research engineers of *Cornell Aeronautical Laboratory* and the staff of the Crash Injury Research projects of the *Cornell University Medical College*.

**1968** To *Christopher S. Cockerell* and *Richard Stanton-Jones* and Citation to the men and women of the *British Hovercraft Corporation* for the design, construction and application of a family of commercially useful Hovercraft.

**1969** To *Douglas C. MacMillan*, *M. Nielsen* and *Edward L. Teale, Jr.* and Citations to *Wilbert C. Gumprich* and the organizations of *George G. Sharp, Inc.*, *Babcock and Wilcox Company*, and the *New York Shipbuilding Corporation* for the design and construction of the N.S. Savannah, the first nuclear ship with reactor, to be operated for commercial purposes.

**1970** To *Charles Stark Draper* and Citations to the personnel of the *MIT Instrumentation Laboratories*, *Delco Electronics Division*, *General Motors Corporation*, and *Aero Products Division*, *Litton Systems*, for the successful application of inertial guidance systems to commercial air navigation.

**1971** To *Sedgwick N. Wight* (in memoriam) and *George W. Baughman* and Citations to *William D. Hailes*, *Lloyd V. Lewis*, *Clarence S. Snavely*, *Herbert A. Wallace*, and the employees of *General Railway Signal Company*, and the *Signal & Communications Division*, *Westinghouse Air Brake Company*, for development of Centralized Traffic Control on railways.

**1972** To *Leonard S. Hobbs* and *Perry W. Pratt* and the dedicated engineers of the *Pratt & Whitney Aircraft Division* of *United Aircraft Corporation* for the design and development of the JT-3 turbo jet engine.

**1975** To *Jerome L. Goldman*, *Frank A. Nemeč* and *James J. Henry* and Citations to the naval architects and marine engineers of *Friede and Goldman, Inc.* and *Alfred W. Schwendtner* for revolutionizing marine cargo transport through the design and development of barge carrying cargo vessels.

**1977** To *Clifford L. Eastburg* and *Harley J. Urbach* and Citations to the *Railroad Engineering Department* of *The Timken Company* for the development, subsequent improvement, manufacture and application of tapered roller bearings for railroad and industrial uses.

**1978** To *Robert Puiseux* and Citations to the employees of the *Manufacture Française des Pneumatiques Michelin* for the development of the radial tire.

**1979** To *Leslie J. Clark* for his contributions to the conceptualization and initial development of the sea transport of liquefied natural gas.

**1980** To *William M. Allen, Malcolm T. Stamper, Joseph F. Sutter* and *Everette L. Webb* and Citations to the employees of *Boeing Commercial Airplane Company* for their leadership in the development, successful introduction and acceptance of wide-body jet aircraft for commercial service.

**1981** To *Edward J. Wasp* for his contributions toward the development and application of long distance pipeline slurry transport of coal and other finely divided solid materials.

**1982** To *Jörg Brenneisen, Ehrhard Futterlieb, Joachim Körber, Edmund Müller, G. Reiner Nill, Manfred Schulz, Herbert Stemmler* and *Werner Teich* for their contributions to the development and application of solid state adjustable frequency induction motor transmission to diesel and electric motor locomotives in heavy freight and passenger service.

**1983** To *Sir George Edwards, OM, CBE, FRS; General Henri Ziegler, CBE, CVO, LM, CG; Sir Stanley Hooker, CBE, FRS* (in memoriam); *Sir Archibald Russell, CBE, FRS*; and *M. André Turcat, L d'H, CG*; commemorating their outstanding international contributions to the successful introduction and subsequent safe service of commercial supersonic aircraft exemplified by the Concorde.

**1984** To *Frederick Aronowitz, Joseph E. Killpatrick, Warren M. Macek* and *Theodore J. Podgorski* for the conception of the principles and development of a ring laser gyroscopic system incorporated in a new series of commercial jet liners and other vehicles.

**1985** To *Richard K. Quinn, Carlton E. Tripp,* and *George H. Plude* for the inclusion of numerous innovative design concepts and an unusual method of construction of the first 1,000-foot self-unloading Great Lakes vessel, the M/V Stewart J. Cort.

**1986** To *George W. Jeffs, Dr. William R. Lucas, Dr. George E. Mueller, George F. Page, Robert F. Thompson* and *John F. Yardley* for significant personal and technical contributions to the concept and achievement of a reusable Space Transportation System.

**1987** To *Harry R. Wetenkamp* for his contributions toward the development and application of curved plate railroad wheel designs.

**1988** To *J. A. Pierce* for his pioneering work and technical achievements that led to the establishment of the OMEGA Navigation System, the world's first ground-based global navigation system.

**1989** To *Harold E. Froehlich, Charles B. Momsen, Jr.,* and *Allyn C. Vine* for the invention, development and deployment of the deep-diving submarine, Alvin.

- 1990** To *Claud M. Davis, Richard B. Hanrahan, John F. Keeley, and James H. Mollenauer* for the conception, design, development and delivery of the Federal Aviation Administration enroute air traffic control system.
- 1991** To *Malcom Purcell McLean* for his pioneering work in revolutionizing cargo transportation through the introduction of intermodal containerization.
- 1992** To *Daniel K. Ludwig* (in memoriam) for the design, development and construction of the modern supertanker.
- 1993** To *Heinz Leiber, Wolf-Dieter Jonner and Hans Jürgen Gerstenmeier* and Citations to their colleagues in *Robert Bosch GmbH* for their conception, design and development of the Anti-lock Braking System for application in motor vehicles.
- 1994** To *Russell G. Altherr* for the conception, design and development of a slackfree connector for articulated railroad freight cars.
- 1996** To *Thomas G. Butler* (in memoriam) and *Richard H. MacNeal* for the development and mechanization of NASA Structural Analysis (NASTRAN) for widespread utilization as a working tool for finite element computation.
- 1998** To *Bradford W. Parkinson* for leading the concept development and early implementation of the Global Positioning System (GPS) as a breakthrough technology for the precise navigation and position determination of transportation vehicles.
- 2000** To those individuals who, working at the French National Railroad (SNCF) and ALSTOM between 1965 and 1981, played leading roles in conceiving and creating the initial TGV High Speed Rail System, which opened a new era in passenger rail transportation in France and beyond.
- 2002** To *Raymond Pearson* for the invention, development and worldwide implementation of a new system for lifting ships out of the water for repair and for launching new ship construction. The simplicity of this concept has allowed both large and small nations to benefit by increasing the efficiency and reducing the cost of shipyard operations.

# The 2004 Elmer A. Sperry Board of Award

EDWARD L. ANDERSON, CHAIR                      JACK V. BOUGH  
Society of Automotive Engineers

BARNEY F. GORIN, VICE CHAIR                      RICHARD DAWSON  
American Society of Mechanical Engineers

HARVEY GLICKENSTEIN                      ALAN F. RUMSEY  
Institute of Electrical and Electronics Engineers

YVONNE BRILL                      G.P. PETERSON  
American Institute of Aeronautics and Astronautics

WILLIAM A. FIFE                      EVA LERNER-LAM  
American Society of Civil Engineers

PERRY W. NELSON                      JOHN M. DEMPSEY, JR.  
Society of Naval Architects and Marine Engineers

## Honorary Members

JOSEPH U. CASTELLANI

CLAUD M. DAVIS

BERNARD J. ECK

FRANK G. FISHER

STUART M. FREY

ALBERT A. GRANT

E. THOMAS HARLEY

V. TERREY HAWTHORNE

JOHN L. HORTON

RONALD K. KISS

BERNARD KOFF

SPERRY LEA

ROGER D. MADDEN

STANLEY I. MAST

GORDON MCKINZIE

L.A. MCLEAN

LAVERE MERRITT

WILLIAM S. PETERS

ROBERT I. PRICE

ROGER D. SCHAUFELE

EUGENE SCHORSCH

CARL S. SELINGER

CHARLES W. STAHLEY

ROY P. TROWBRIDGE

ROBERT J. WEAR

GILBERT M. WHITLOW

JAMES R. WITTMAYER

## Correspondent

ELMER A. SPERRY, III

## Secretary

DAVID J. SOUKUP



MS8005